

**CODI® S** with stuffing box

**CODI® B** with bellows seal (maintenance-free)



**Prefabricated compact manifolds for condensate collection and steam distribution**

**PN40 / PN63**  
**CODI® 02 up to 18 - with socket weld ends**  
**CODI® 02 up to 18 - with butt weld ends**

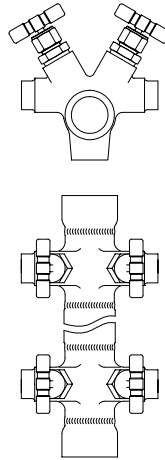

Forged steel

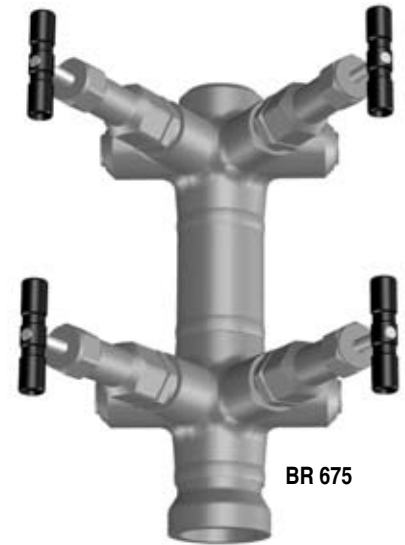

BR 675

**CODI® S**  
with stuffing box:

**BR 671 (vertical installation)**  
**BR 672 (horizontal installation)**

**CODI® B**  
with bellows seal:

**BR 675 (vertical installation)**  
**BR 676 (horizontal installation)**

**BR ... -14**    **BR ... -12**    **BR ... -10**    **BR ... -08**    **BR ... -06**    **BR ... -04**    **BR ... -02**

**Features:**

- Flexibility through compact, modular design (available with 2, 4, 6, 8, 10, 12, 14, 16 or 18 integrated stop valves!)
- All functional parts replaceable in situ - no need for manifold removal!
- Valves with low maintenance (CODI® S - BR 671 / 672 ) or maintenance-free (CODI® B - BR 675 / 676) with open-close or throttling function.
- Safety back seat when fully opened valve!
- Economic on-site handling and long life through forged steel
- An insulating jacket provides optimal protection against energy loss (optional) !

Manifolds for condensate collection and steam distribution made of forged steel

**CODI® S**

BR 671 / 672

Design with stuffing box

Module complete

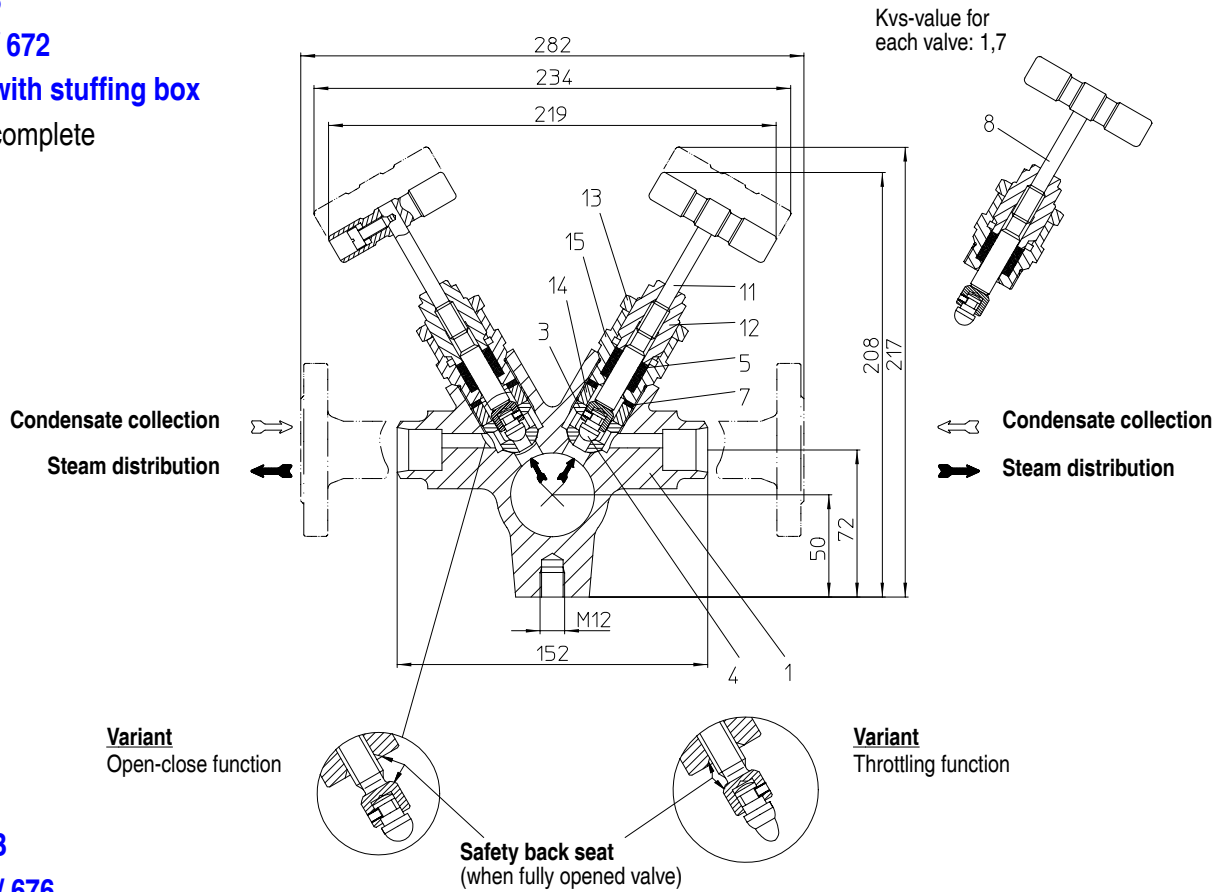

**CODI® B**

BR 675 / 676

Design with bellows seal

Module complete

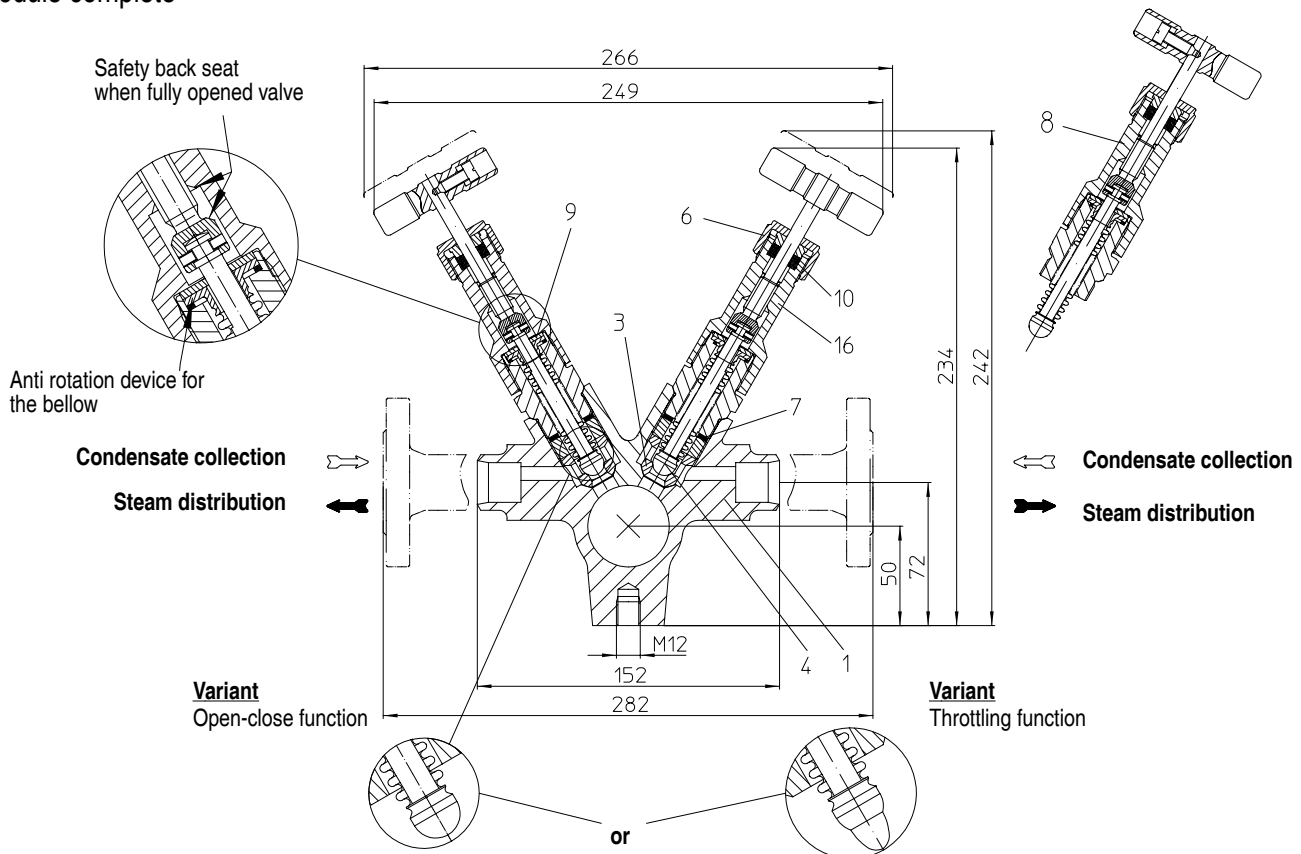

**Parts**

Pos.	Description	Material, (Material-No.)			
		DIN	comparable with ASTM / AISI	DIN	comparable with ASTM / AISI
1	Body	C22.8, 1.0460	SA 105	X2CrNiMo17-12-2, 1.4404	SA 182 F316L
2	Connection between the modules	St 35.8, 1.0345	SA 106 Gr. A	X2CrNiMo17-12-2, 1.4404	SA 182 F316L
3	Seat *	X8CrNiS18-9, 1.4305	AISI 303	X8CrNiS18-9, 1.4305	AISI 303
4	Valve ball	X39CrMo17-1+QT, 1.4122+QT	AISI 420 RM	X39CrMo17-1+QT, 1.4122+QT	AISI 420 RM
5	Packing ring (1 set for CODI®S) *	Graphite		Graphite	
6	Sleeve nuts	X14CrMoS17+QT, 1.4104+QT	AISI 430 F	X14CrMoS17+QT, 1.4104+QT	AISI 430 F
7	Graphit ring	Graphite		Graphite	
8	Assembly stop valve, cpl. *	X6CrNiMoTi17-12-2, 1.4571	SA 240	X6CrNiMoTi17-12-2, 1.4571	SA 240
8.1	Bellows seal	Stainless steel		Stainless steel	
9	Safety washer	X5CrNi18-10, 1.4301	SA 240	X5CrNi18-10, 1.4301	SA 240
10	Packing ring (1 set for CODI®B) *	Graphite		Graphite	
11	Stem	X2CrNiMo17-12-2, 1.4404	SA 351 CF-3M	X2CrNiMo17-12-2, 1.4404	SA 351 CF-3M
12	Threaded bush	X39CrMo17-1+QT, 1.4122+QT	AISI 420 RM	X39CrMo17-1+QT, 1.4122+QT	AISI 420 RM
13	Safety nut	X8CrNiS18-9, 1.4305	AISI 303	X8CrNiS18-9, 1.4305	AISI 303
14	Banjo bolt	X8CrNiS18-9, 1.4305	AISI 303	X8CrNiS18-9, 1.4305	AISI 303
15	Fitting	X8CrNiS18-9, 1.4305	AISI 303	X8CrNiS18-9, 1.4305	AISI 303
16	Spindle guiding	X8CrNiS18-9, 1.4305	AISI 303	X8CrNiS18-9, 1.4305	AISI 303
	Other interior parts	Stainless steel		Stainless steel	

\* Spare parts

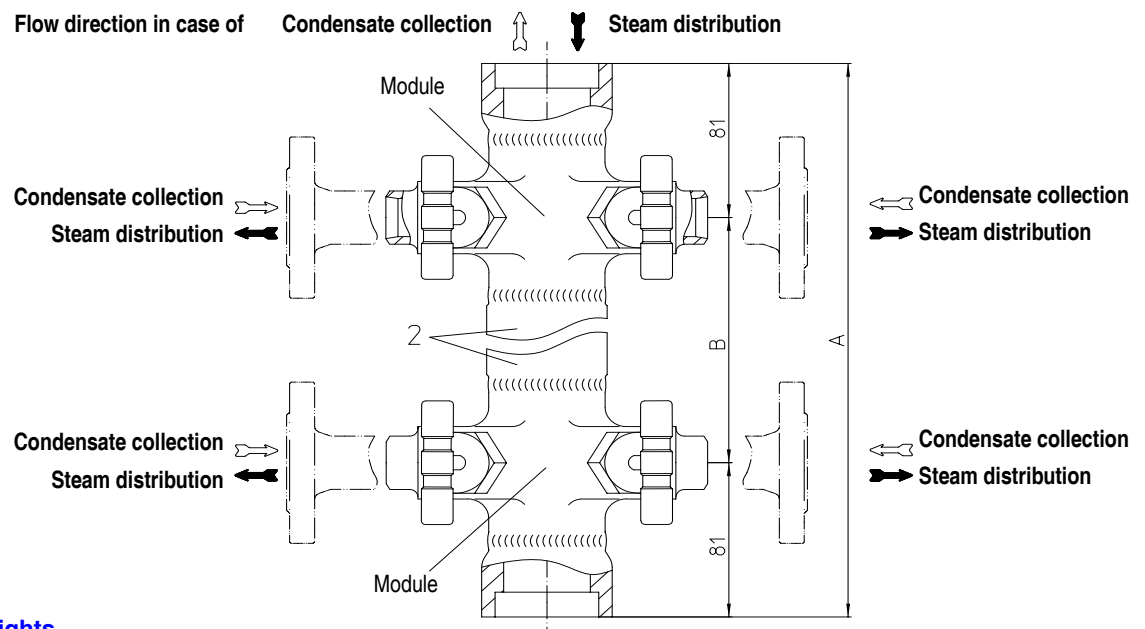
**Dimensions and weights**

Type			BR ... -02	BR ... -04	BR ... -06	BR ... -08	BR ... -10	BR ... -12	BR ... -14	BR ... -16	BR ... -18
Dimension A	PN 40 Class 300	B = 120	162	282	402	522	642	762	882	1002	1122
	PN 40 Class 300	B = 160	162	322	482	642	802	962	1122	1282	1442
	PN 63	B = 185	162	347	532	717	902	1087	1272	1457	1642
Weight approximate in kg	PN 40 Class 300	B = 120	3,5	7,2	10,7	14,7	17,7	21,2	24,7	28,2	31,7
	PN 40 Class 300	B = 160	3,5	7,5	11	14,5	18	21,5	25	28,5	32
	PN 63	B = 185	4	8,5	12,5	16,5	20,5	24,5	28,5	32,5	36,5

Operating limits	PN40 - C22.8	
Operating pressure PB (bar-Ü)	32	21
Operating temperature TB (°C)	250	400

Operating limits	PN40 - 1.4404	
Operating pressure PB (bar-Ü)	32	22
Operating temperature TB (°C)	350	400

Operating limits	PN63 - C22.8	
Operating pressure PB (bar-Ü)	45	32
Operating temperature TB (°C)	250	400

Standard design	
Primary connection top and bottom:	
DN 40	Socket weld ends acc. to DIN EN 12760
1 1/2 inch	Socket weld ends acc. to ANSI 300
Secondary connection left and right:	
BR ... -02	each 1 secondary connections DN15 or 1/2 inch
BR ... -04	each 2 secondary connections DN15 or 1/2 inch
BR ... -06	each 3 secondary connections DN15 or 1/2 inch
BR ... -08	each 4 secondary connections DN15 or 1/2 inch
BR ... -10	each 5 secondary connections DN15 or 1/2 inch
BR ... -12	each 6 secondary connections DN15 or 1/2 inch
BR ... -14	each 7 secondary connections DN15 or 1/2 inch
BR ... -16	each 8 secondary connections DN15 or 1/2 inch
BR ... -18	each 9 secondary connections DN15 or 1/2 inch
Other types of connection on request.	

### Basic types are:

vertical installation	horizontal installation
BR 671 / 675 - 02	
BR 671 / 675 - 04	BR 672 / 676 - 02
BR 671 / 675 - 06	BR 672 / 676 - 03
BR 671 / 675 - 08	BR 672 / 676 - 04
BR 671 / 675 - 10	BR 672 / 676 - 05
BR 671 / 675 - 12	BR 672 / 676 - 06
BR 671 / 675 - 14	BR 672 / 676 - 07
BR 671 / 675 - 16	BR 672 / 676 - 08
BR 671 / 675 - 18	BR 672 / 676 - 09

Installation position preferably vertical. Threaded connection M12 are provided at the back for the attachment to a supporting structure. For the attachment is recommended:

BR 671 / 675 - 02	1 screw
BR 671 / 675 - 04	2 screws
BR 671 / 675 - 06	3 screws
BR 671 / 675 - 08	3 screws
BR 671 / 675 - 10	4 screws
BR 671 / 675 - 12	4 screws
BR 671 / 675 - 14	5 screws
BR 671 / 675 - 16	5 screws
BR 671 / 675 - 18	6 screws
BR 672 / 676 - 02	1 screw
BR 672 / 676 - 03	2 screws
BR 672 / 676 - 04	3 screws
BR 672 / 676 - 05	3 screws
BR 672 / 676 - 06	4 screws
BR 672 / 676 - 07	4 screws
BR 672 / 676 - 08	5 screws
BR 672 / 676 - 09	5 screws

## Operating ranges

BR 671/672 and BR 675/676 both can be applied as condensate collector or steam distributor. Applications are wide spread piping systems, steam tracers on pipes and apparatus. The flow media can be steam, water, oil etc.

On the application as steam distributor the steam inlet is at the top flange. At the bottom outlet flange a steam trap shall be installed.

On the application as condensate collector the outlet is at the top flange. At the bottom flange a blowdown valve shall be installed.

In case of a vertical installation a siphon pipe should be applied. This ensures even temperature distribution thus pressure shocks and noise on condensate return are reduced.

The design is based on a robust module construction with integral stop valves (ball/seat). Body and stop valve are threaded together with a hard seal (metal to metal).

Integral stop valves on CODI® S require low maintenance. All functional parts are replaceable in situ. There is no need for manifold removal from the pipe. BR 676 (CODI® B bellows seal design for horizontal installation) and BR 675 (CODI® B bellows seal design for vertical installation) are designed for those installations where we find the highest requirements for tight sealing to the open and maintenance free operation of the valve.

A clearance of 50 mm between the construction bracket and the condensate collector/steam distributor ensures that the insulation jacket can be wrapped around it.

During welding at the primary and secondary connections the integral stop valves have to be in an open position.

Further precautions are not required.

## Handling

The integral stop valves with shut-off plugs shall not be used for throttling of condensate-or steam flows.

For throttling purposes the throttling plug shall be applied.

The valves are generally equipped with back seats. The advantage of BR 671/672 is that this additional back seat sealing protects the

The advantage of BR 671/672 is that this additional back seat sealing protects the graphite packing and multiples its longevity.

On BR 675/676 the back seat may be advantageous in case of damages to the bellows.

On CODI® B 675/676 no twist to the bellow will be effected due to the non-rotation lock.

The stop valves are screwed into the body without using a gasket (hard seal)

If necessary, the union nut (pos. 6) can be tightened, but the stem must to be turned with normal forces!

## Insulating jacket / pipe connection

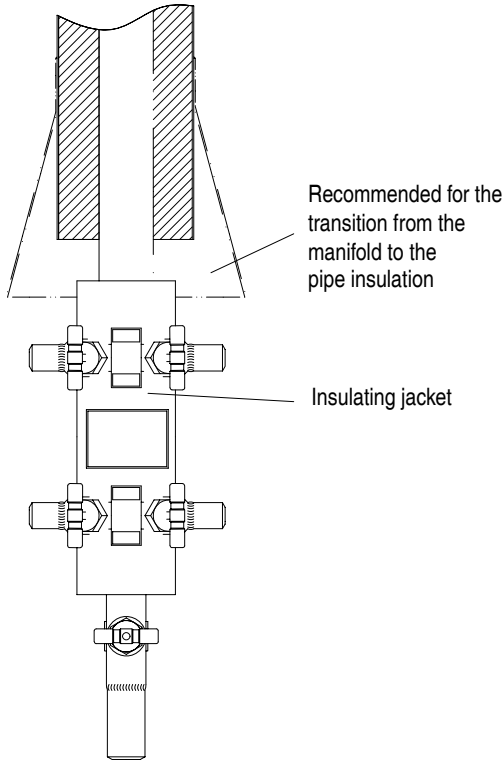

Insulating jacket in mounted position

**Cona insulating jackets provide a simple and effective heat insulation**  
(suitable for every condensate collection / steam distribution)

**Advantages:**

- energy saving
- less radiation of heat to the atmosphere
- safety of the operation personal
- robust, non ageing
- resistance to heat
- low weight and flexible
- clean handling (no contact with the insulating material)
- free from asbestos
- water repellent
- simple disassembly and reusable

## Immersion tube

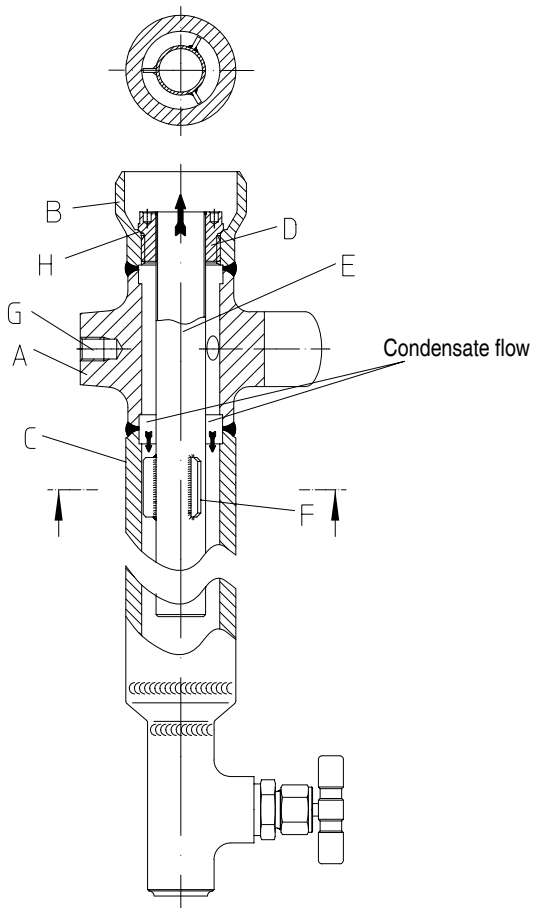

Condensate collector with immersion tube

Part	Description
A	CODI <sup>®</sup> module
B	Butt weld end
C	Welding bushing for the connection with an additional module
D	Banjo bolt X 5 CrNi 18-10-3a (1.4301)
E	Immersion tube X 6 CrNiTi 18-10 (1.4541)
F	Spacer X 5 CrNi 18-10-3a (1.4301)
G	Fixing point
H	Metal-to-metal seal between banjo bolt and welding bush

**preferred  
vertical installation**

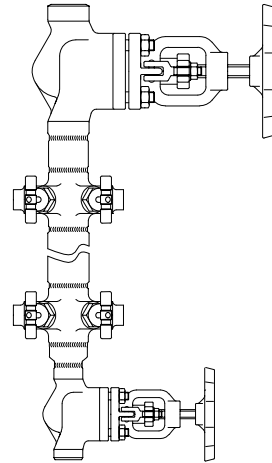
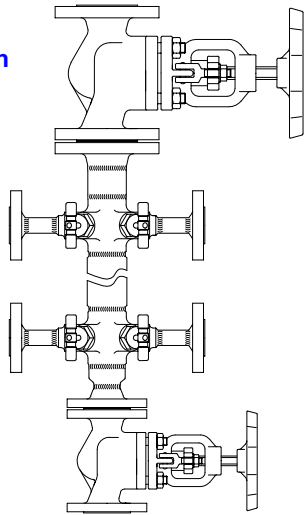

- ... **primary stop valve (flanged) for welding neck flange**  
DN40 acc. to DIN 2635 or DIN 2637 resp. DN 50 acc. to DIN 2635 or DIN 2636  
1 1/2" and 2" acc. to ANSI B16.5 Class 300 or Class 600
- ... **secondary connections (flanged)**  
DN15 up to DN25 acc. to DIN 2635 or DIN 2637  
1/2" up to 1" acc. to ANSI B16.5 Class 300 or Class 600
- ... **design with blow down valve**

- ... **primary stop valve (butt weld ends)**  
DN40 and DN50 acc. to DIN EN 12627  
1 1/2" and 2" acc. to ANSI B16.25
- ... **secondary connections (butt weld ends)**  
DN15 up to DN25 acc. to DIN EN 12627  
1/2" up to 1" acc. to ANSI B16.25
- ... **design with blow down valve**

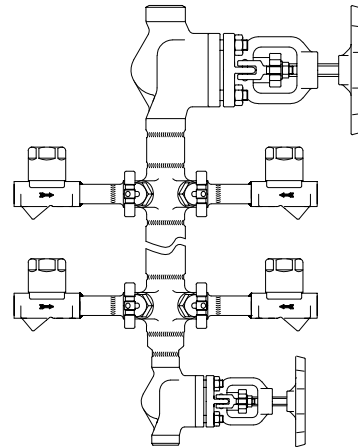
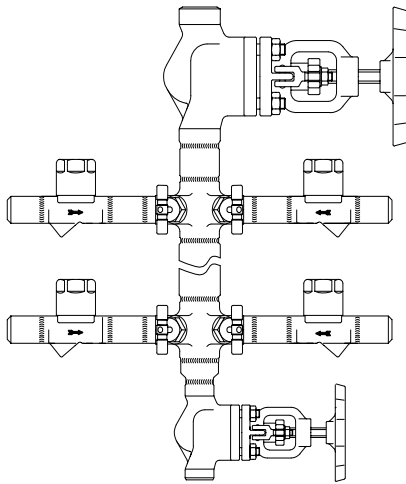

- ... **primary stop valve (butt weld ends)**  
DN40 and DN50 acc. to DIN EN 12627  
1 1/2" and 2" acc. to ANSI B16.25
- ... **secondary connections with steam trap (butt weld ends)**  
DN15 up to DN25 acc. to DIN EN 12627  
1/2" up to 1" acc. to ANSI B16.25
- ... **design with blow down valve**

- ... **primary stop valve (butt weld ends)**  
DN40 and DN50 acc. to DIN EN 12627  
1 1/2" and 2" acc. to ANSI B16.25
- ... **secondary connections with steam trap (socket weld ends)**  
DN15 and DN20 acc. to DIN EN 12760  
1/2" and 3/4" acc. to ANSI B16.11 Class 300
- ... **design with blow down valve**

**Horizontal installation**

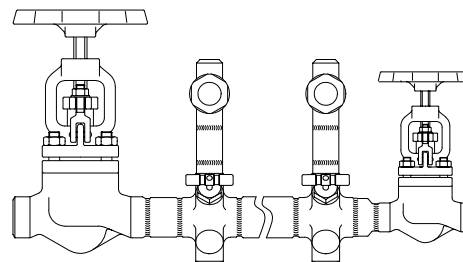
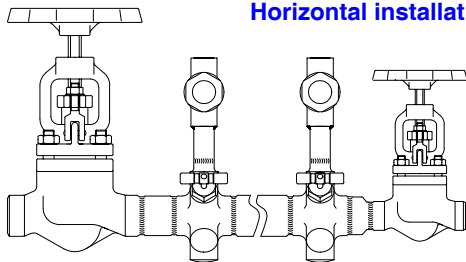

- ... **primary stop valve (butt weld ends)**  
DN40 and DN50 acc. to DIN EN 12627  
1 1/2" and 2" acc. to ANSI B16.25
- ... **secondary connections with steam trap (socket weld ends or butt weld ends)**  
DN15 and DN25 acc. to DIN EN 12760 or DN15 and DN25 acc. to DIN EN 12627 (butt weld ends)  
1/2" and 3/4" acc. to ANSI B16.11 oder 1/2" up to 1" acc. to ANSI B16.5
- ... **design with blow down valve**

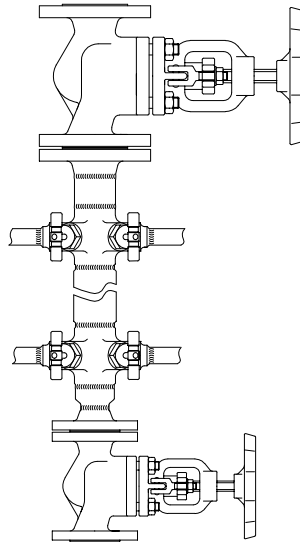

... primary stop valve and secondary connections - design with blow down valve

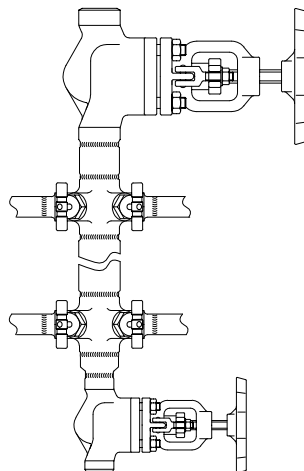

... primary stop valve, secondary connections - design with blow down valve



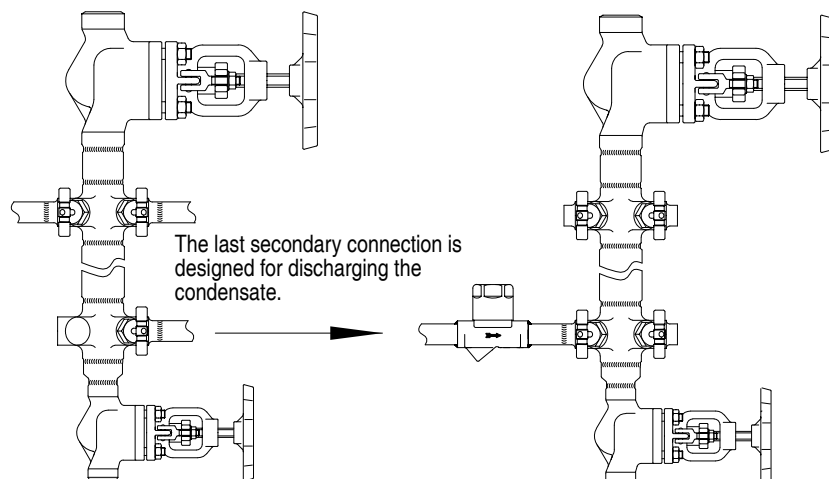

**Steam distribution**

**Condensate collection**

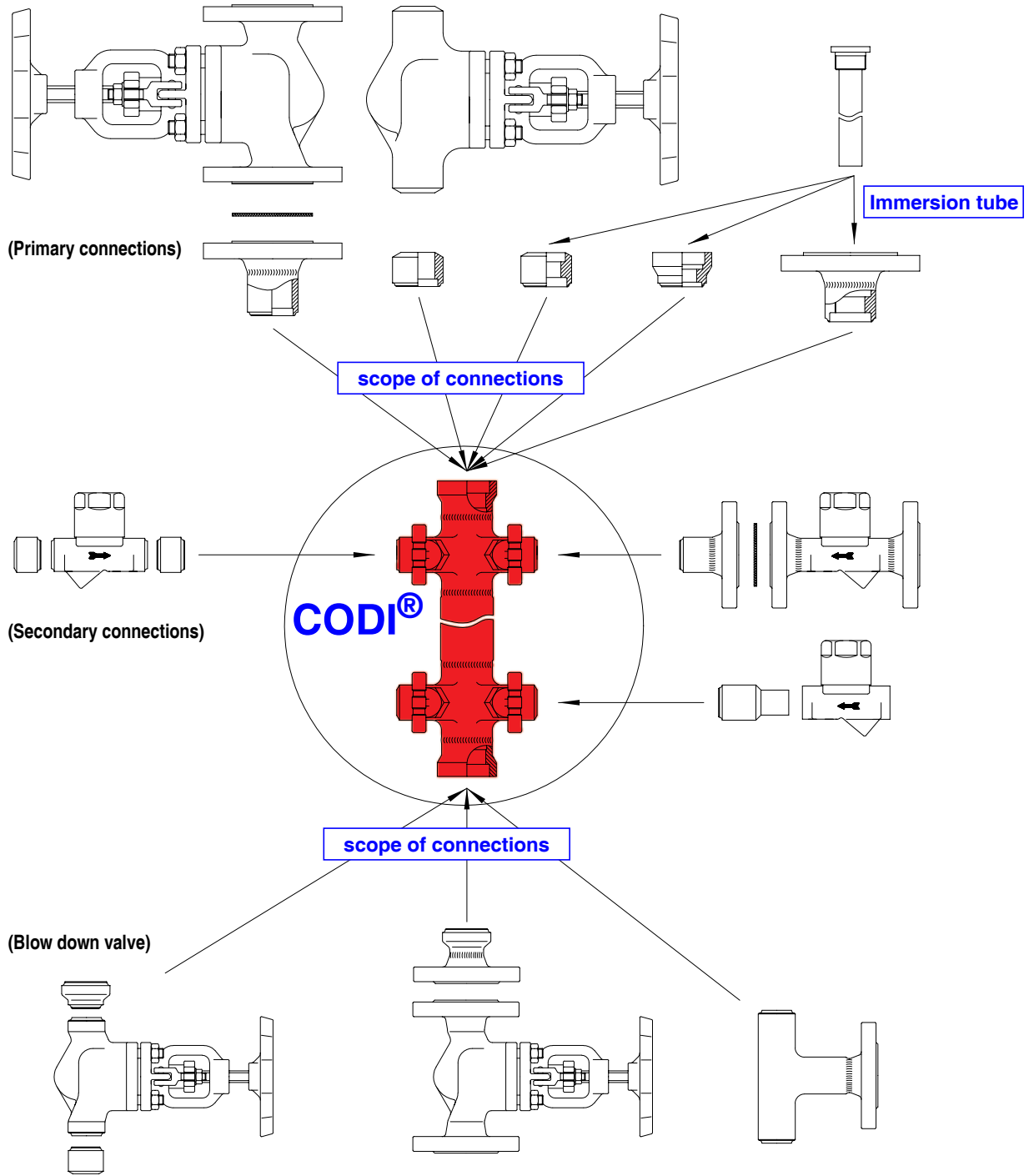

... primary stop valve, secondary connections - design with blow down valve - steam trap at the condensate collector

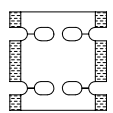

<p><b>Accessories</b></p> <ul style="list-style-type: none"> <li>• 1 set of fastening parts consisting of:</li> </ul> <ul style="list-style-type: none"> <li> - distance sleeve</li> <li> - hexagon bolt M12</li> <li> - washer</li> <li> - washer</li> </ul>	<ul style="list-style-type: none"> <li>• Mounting wrench</li> </ul> 	<ul style="list-style-type: none"> <li>• Insulating jacket preventing radiation of heat</li> </ul> 
---	---	--

**Inquiry- / order-data**

for inquiries or when placing orders, please use the order form attached.



Offer-No.: .....

Inquiry-No.: .....

**Inquiry**

**Order**

Series:

CODI® S with stuffing box

BR 671

BR 672

CODI® B with bellows seal

BR 675

BR 676

Types:

**vertical installation**

**horizontal installation**

BR 671 / 675 - 02

BR 671 / 675 - 04

BR 671 / 675 - 06

BR 671 / 675 - 08

BR 671 / 675 - 10

BR 671 / 675 - 12

BR 671 / 675 - 14

BR 671 / 675 - 16

BR 671 / 675 - 18

BR 672 / 676 - 02

BR 672 / 676 - 03

BR 672 / 676 - 04

BR 672 / 676 - 05

BR 672 / 676 - 06

BR 672 / 676 - 07

BR 672 / 676 - 08

BR 672 / 676 - 09

Application:

Condensate collection

Steam distribution

Type of connection:

Connection		Top Inlet- / Outlet		Bottom Inlet- / Outlet		secondary connection	
		DIN	ANSI	DIN	ANSI	DIN	ANSI
Screwed socket R <sub>p</sub>							
Screwed socket NPT							
Butt weld end							
Socket weld end							
Flange							
DN 15	1/2 "						
DN 20	3/4 "						
DN 25	1 "						
DN 40	1 1/2 "						
DN 50	2 "						

From: .....

.....

.....

.....

Tel.: .....

Fax.: .....

Sizing acc. to:

DIN PN40 - C22.8, 1.0460

DIN PN 40 - X 6 CrNiTi 18-10, 1.4541

DIN PN63 - C22.8, 1.0460

ANSI Class 300 - SA105

ANSI Class 300 - SA182 F321

Certification:

Material certificates acc. to DIN EN 10204 / 2.2

Material certificates acc. to DIN EN 10204 / 3.1B

Compression test:

acc. to DIN 3230

acc. to API 598

Options:

stop valve at the top inlet/outlet

Drainage at the bottom

Tracer (secondary) connection incl. steam traps

Kind of steam trap :  Capsule

Tracer (secondary) connection

Bimetallic controller

incl. return temperature control valve

Thermodynamic controller

Accessories:

Immersion tube

Insulating jacket

Set of fastening parts

Mounting wrench

Flow media:

Steam

Water

Oil

Others .....

Specials:

Number: